

EXPLOSIVE VIEW OF WD041610180

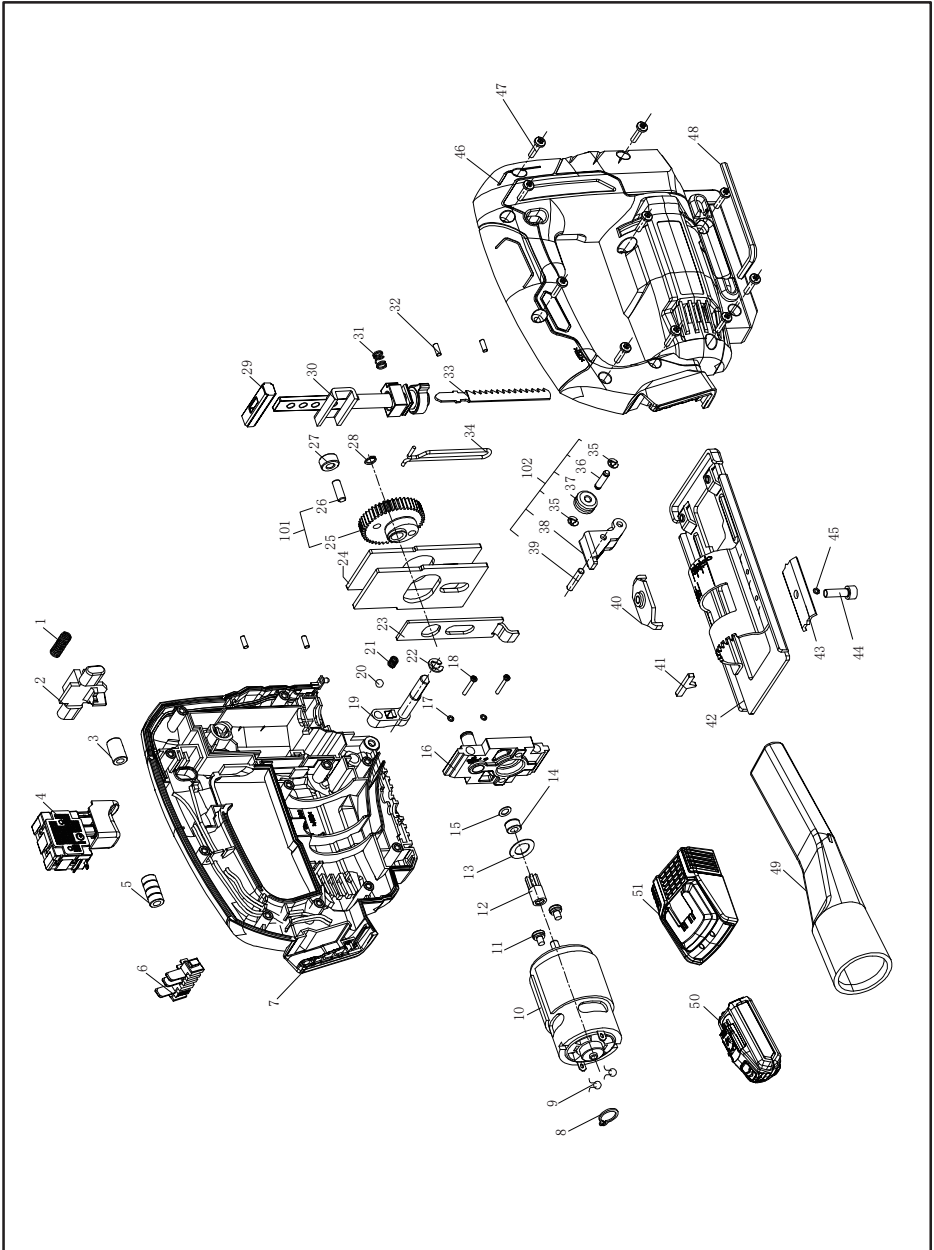

## PART LIST OF WD041610180

NO	DESCRIPTION	Q'TY	NO	DESCRIPTION	Q'TY
1	Spring	1	27	Roller	1
2	Lock-off lever	1	28	Circlip	1
3	Inductor	1	29	Guide plate	1
4	Switch	1	30	Reciprocating shaft	1
5	Inductor	1	31	Spring	1
6	Terminal	1	32	Pin	4
7	Left housing	1	33	Saw blade	1
8	Circlip	1	34	Guard wire	1
9	Capacitor	2	35	Circlip	2
10	Motor	1	36	Pin	1
11	Screw	2	37	Blade guide	1
12	Pinion	1	38	Support board	1
13	Washer	1	39	Roller needle	1
14	Shaft sleeve	1	40	Nut	1
15	Washer	1	41	Location block	1
16	Support	1	42	Base plate	1
17	Spring washer	2	43	Press plate	1
18	Screw	2	44	Hexagon socket head bolt	1
19	Pendulum action control lever	1	45	Washer	1
20	Steel ball	1	46	Right housing	1
21	Spring	1	47	Screw	10
22	Circlip	1	48	Hex key	1
23	Pendulum fork	1	49	Dust tube	1
24	Balance block	2	50	Battery pack	1
25	Gear	1	51	Charger	1
26	Drive spindle	1			